

18242-1
18242-15
18242-18

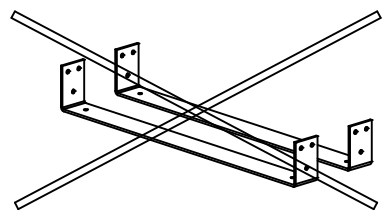

www.plus.dk

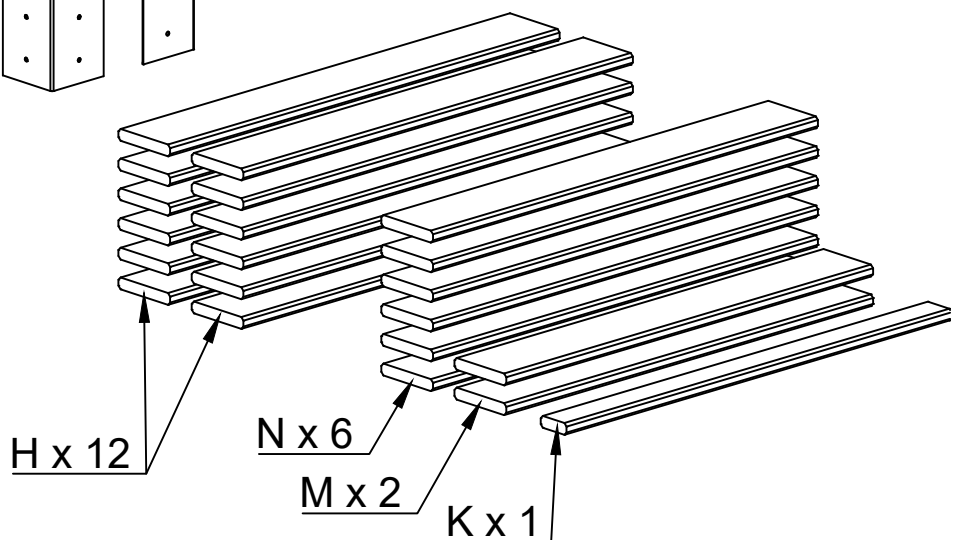
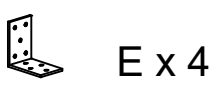
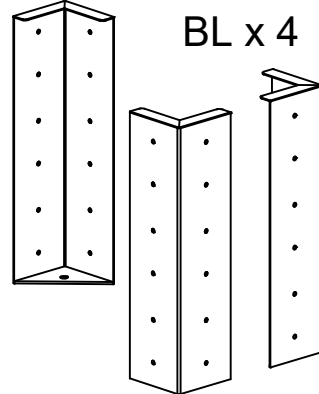
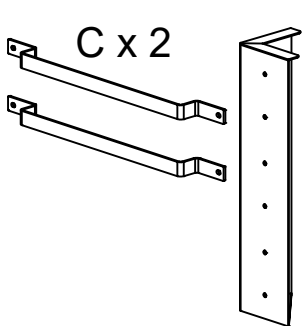
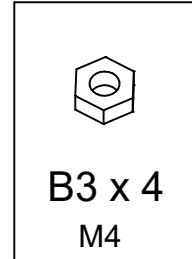
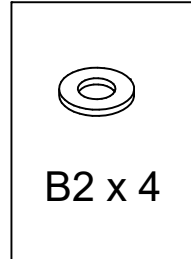
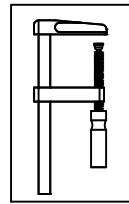
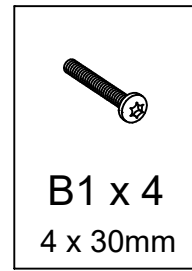
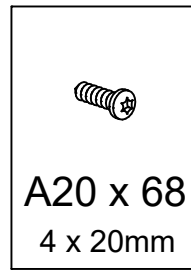
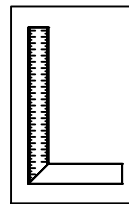
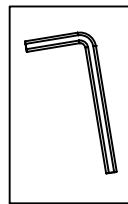
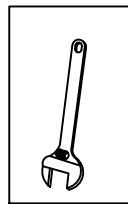
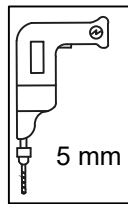
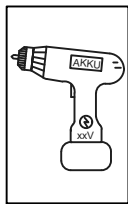
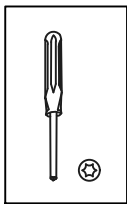
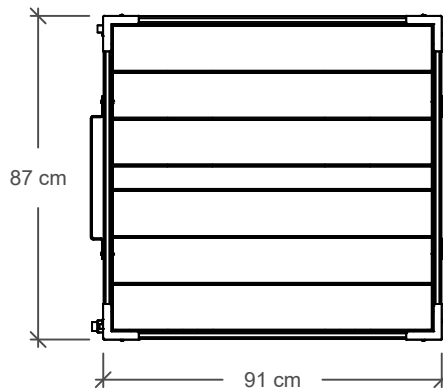
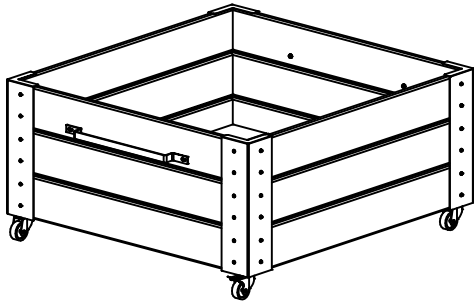

Revideret november 2016
Geändert November 2016
Last update November 2016
Dernière révision novembre 2016

1

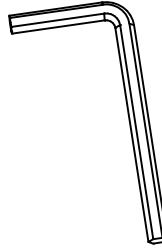
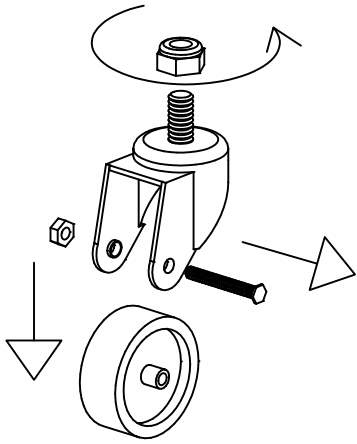

F x 4

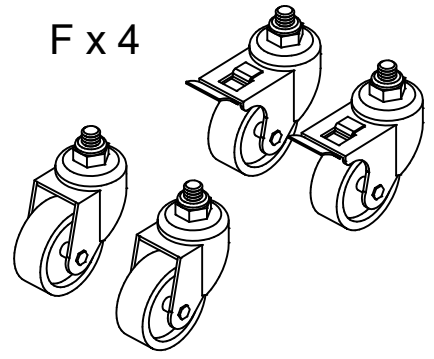

2

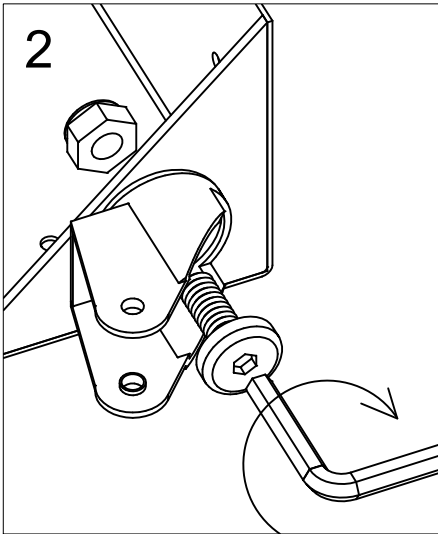

3

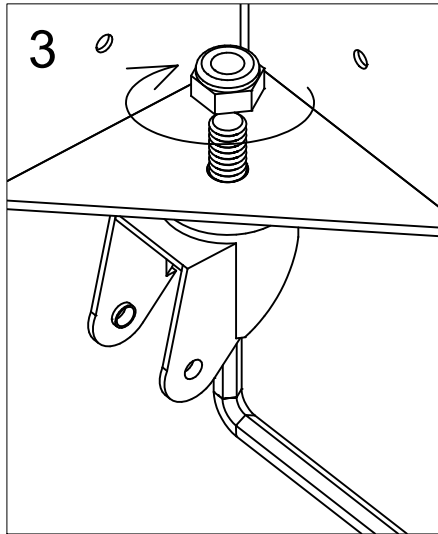

4

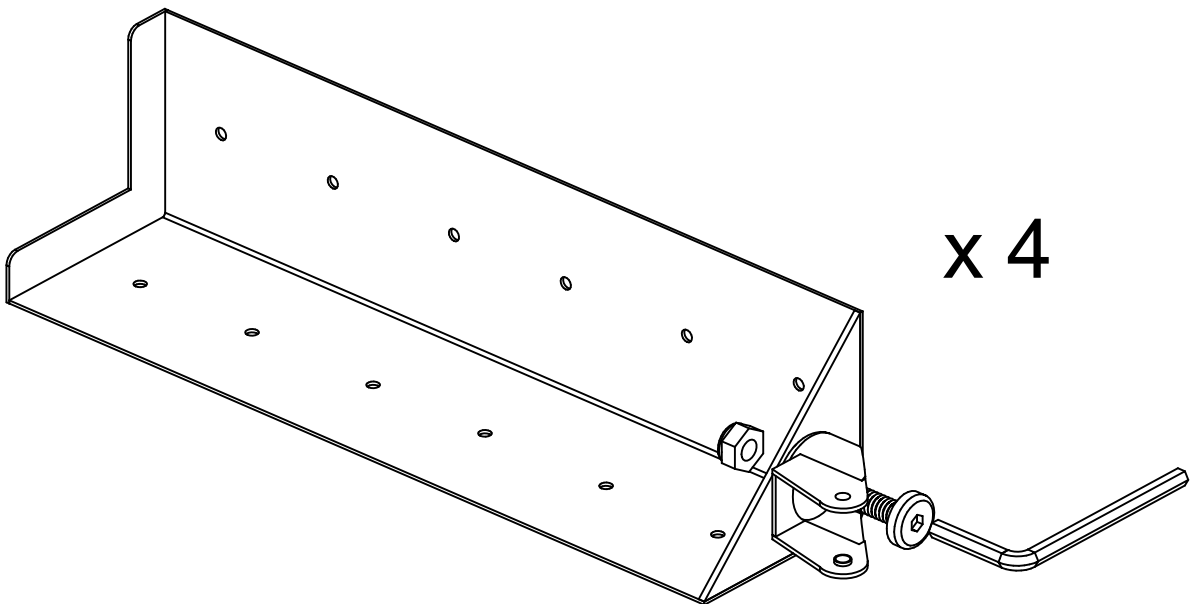
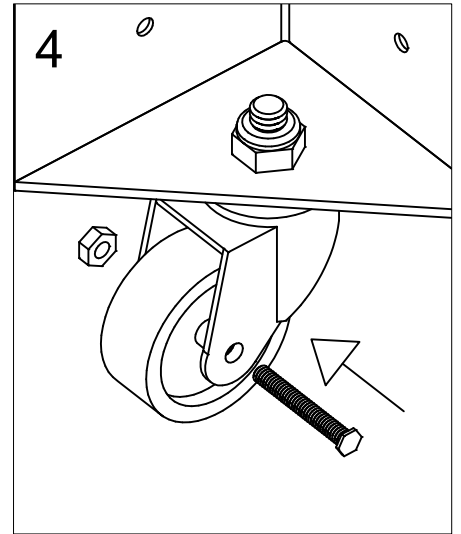

1. Øverste bræt, helt op til kanten.
Top board, right up to the edge.
Oberstes Brett, bis zur Kante anlegen.
Placer la planche supérieure jusqu'au bord.
2. Nederste bræt, helt ned til kanten.
Bottom board, right down to the edge.
Unteres Brett bis zur Kante anlegen.
Placer la planche inférieure jusqu'au bord.
3. Øvrige brædder fordeles jævnt.
Other boards is distributed evenly.
Restliche Bretter gleichmäßig verteilen.
Répartir les autres planches uniformément.

Tip / Tips / Tipps / Conseil !

Brug f.eks. dette værktøj.
Use this tool.
Dieses Werkzeug verwenden.
Utiliser cet outil.

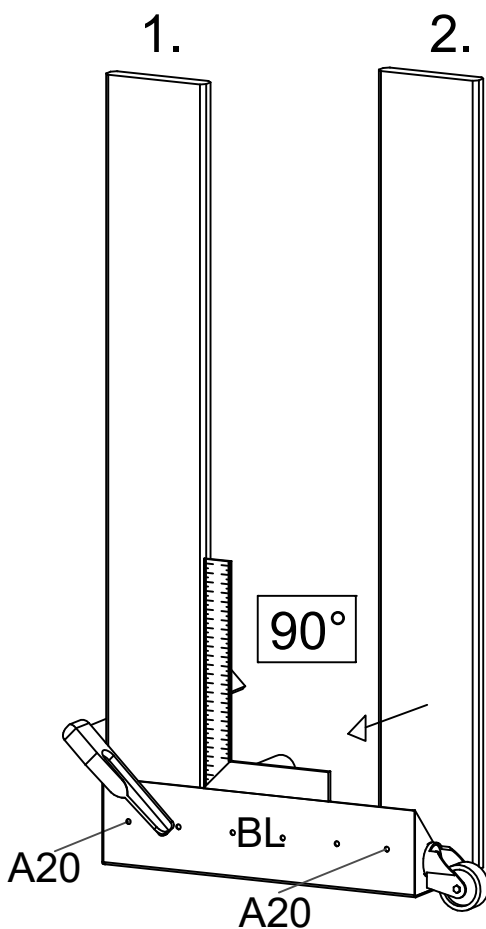
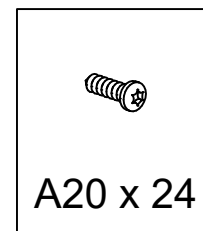
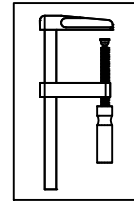
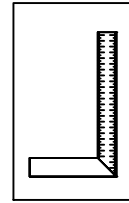

x 2

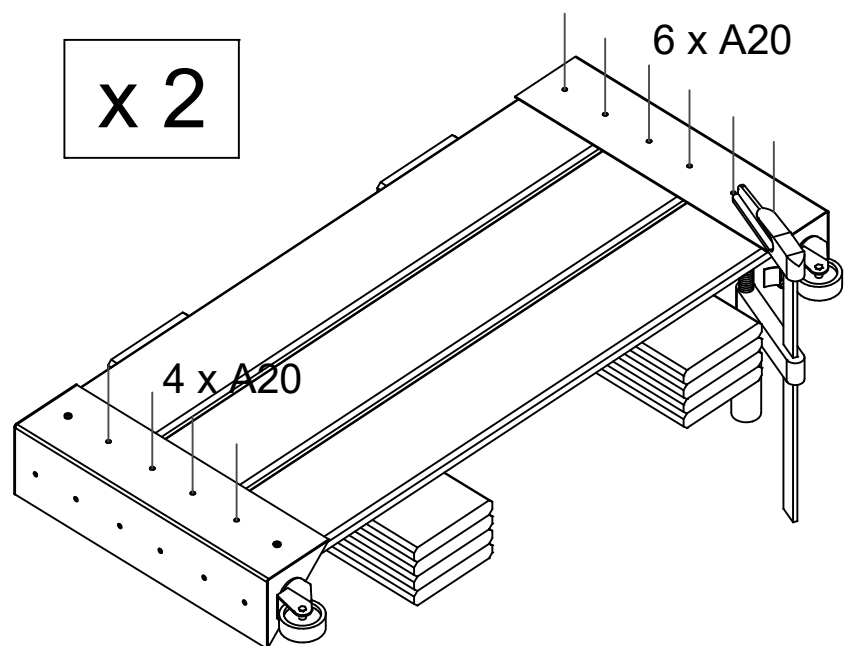

Tip !

Montere kun 1 skrue i hvert bræt, så der er mulighed for justering, når brættet skal fastgøres til det andet hjørne..!

Tips !

Mount only 1 screw in each board, so there is a possibility of adjustment when the board must be fixed to the other corner..!

Tipps !

Vorerst eine Schraube je Brett verwenden, so besteht die Möglichkeit es zu justieren, wenn es an der anderen Ecke montiert wird..!

Conseil !

Utiliser une seule vis par planche pour commencer afin d'avoir la possibilité d'ajuster la planche quand elle est montée de l'autre angle..!

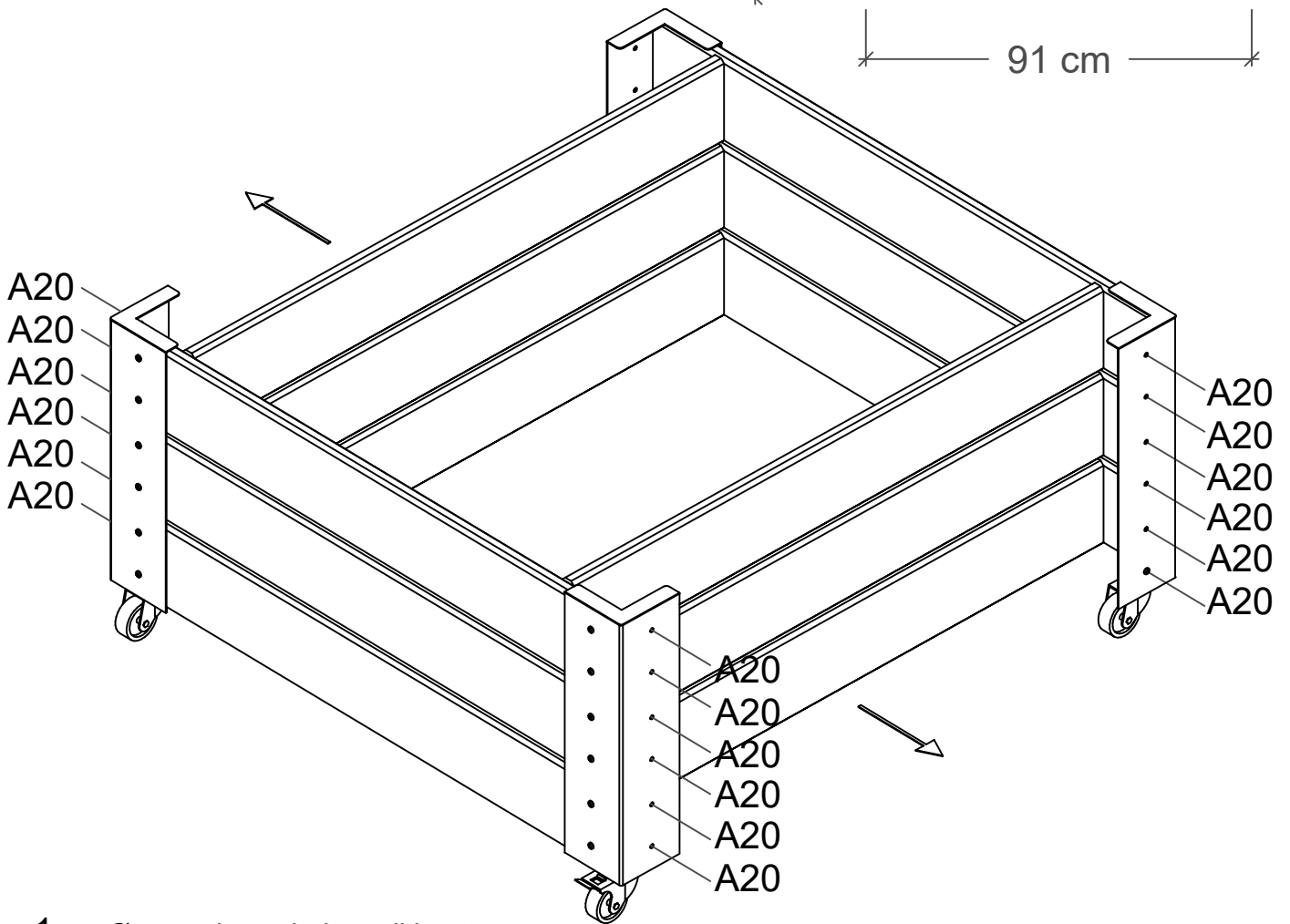
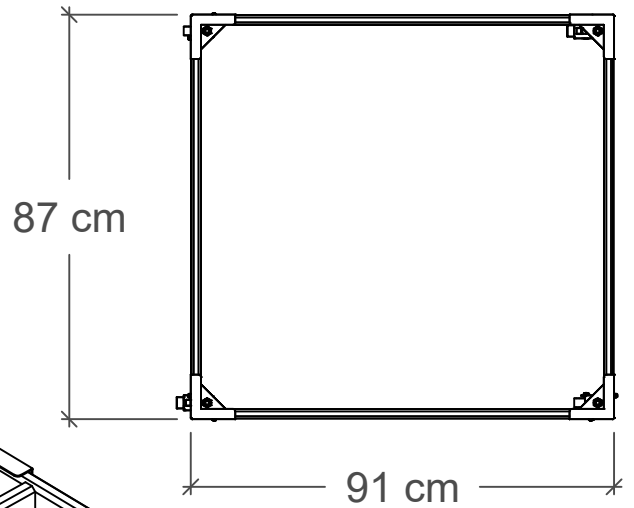
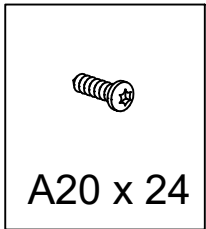

1. Øverste bræt, helt op til kanten.
Top board, right up to the edge.
Oberstes Brett, bis zur Kante anlegen.
Placer la planche supérieure jusqu'au bord.
2. Nederste bræt, helt ned til kanten.
Bottom board, right down to the edge.
Unteres Brett bis zur Kante anlegen.
Placer la planche inférieure jusqu'au bord.
3. Øvrige brædder fordeles jævnt.
Other boards is distributed evenly.
Restliche Bretter gleichmäßig verteiltern.
Répartir les autres planches uniformément.

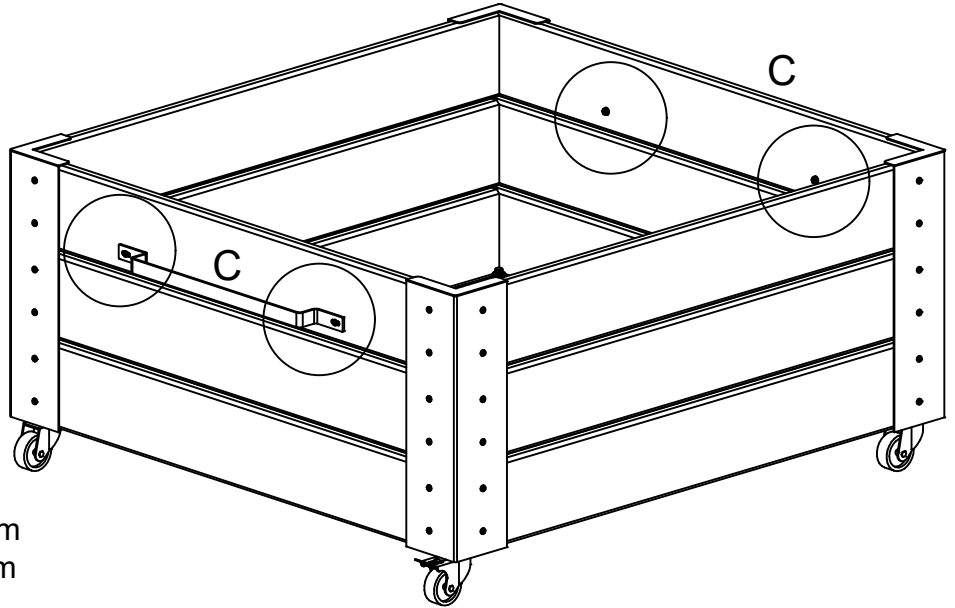
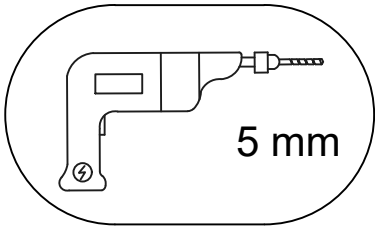
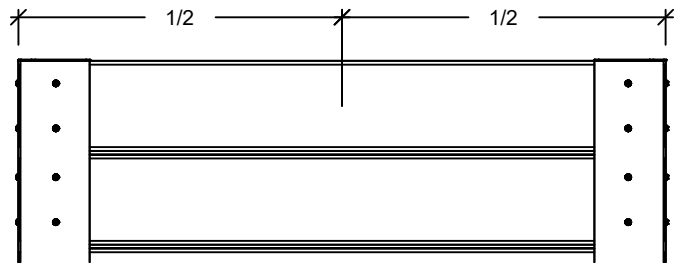
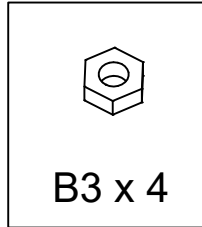
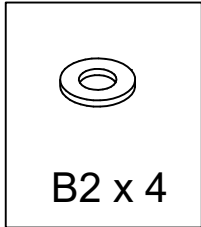
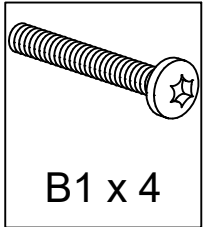

Forbores til bolt - 5 mm.
Pre-drill for bolt - 5 mm
Vorborenen für den Bolzen - 5 mm
Pré-percer pour le boulon - 5 mm

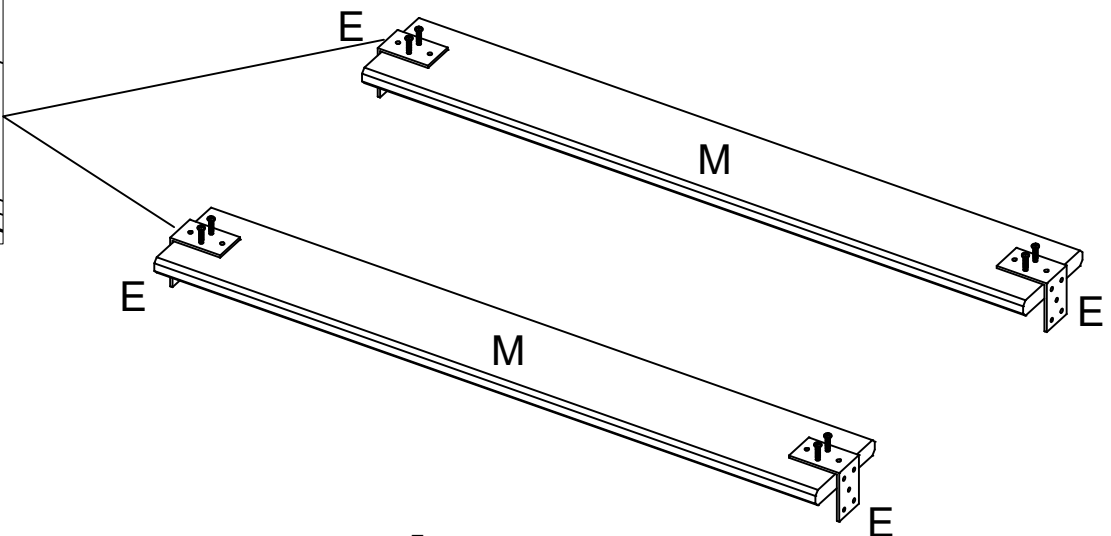
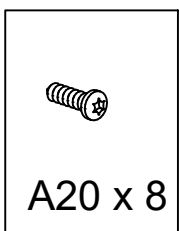
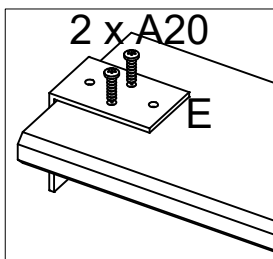
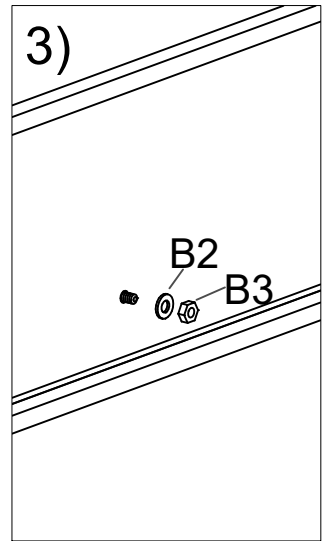
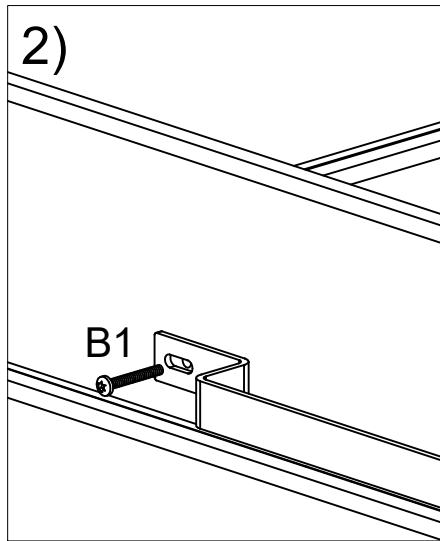
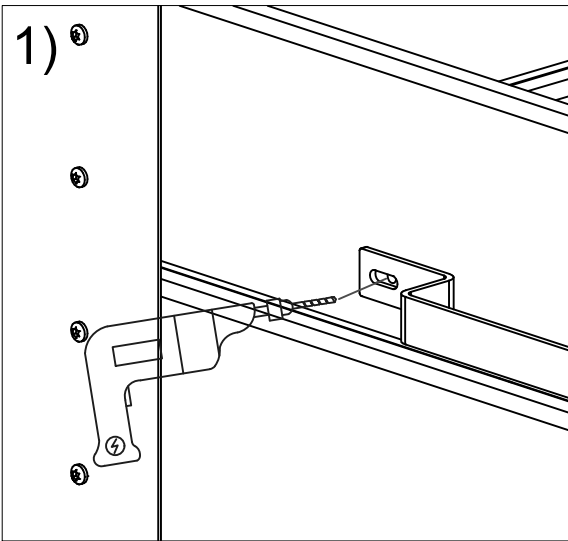

DK

Stål bundlister kan placeres i den højde man ønsker.

Alt efter hvad kassen skal bruges til.

1. Opbevaring.
2. Direkte plantning i jord/muld.

Fiberdug anvendes altid. (fiberdug prikkes, så overskydende vand kan løbe ud).

DE

Je nach Anwendung können die Halterungen der Bodenbretter auf die gewünschte Höhe geschraubt werden.

1. Lagerung
2. Gebrauch von Erde. Verwenden Sie immer das Fasertuch.

Wenn Sie es an einigen Stellen einschneiden, kann überflüssiges Wasser ablaufen.

UK

Steel bottom lists can be placed at the height you desire, depending on what the box is for.

1. Storage
2. Direct planting in soil/composting.

Always use Fiber tex cloth. (The Fiber tex cloth is pierced so excessive water runs out.)

F

En fonction de l'utilisation, les fixations des planches au sol peuvent être vissées à la hauteur désirée.

1. Stockage
2. Utilisation de la terre
Toujours utiliser un chiffon doux. Si vous coupez certains endroits, l'excédent d'eau pourra s'écouler.



+ jord/muld
Blumenerde/Humuserde
soil/compost
de la terre

placering af bundlister
Platzierung der Stahlbügel/Bodenträger
Bottom list position
Emplacement de l'arceau en acier

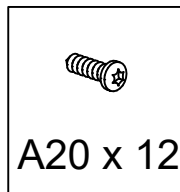

A20 x 12

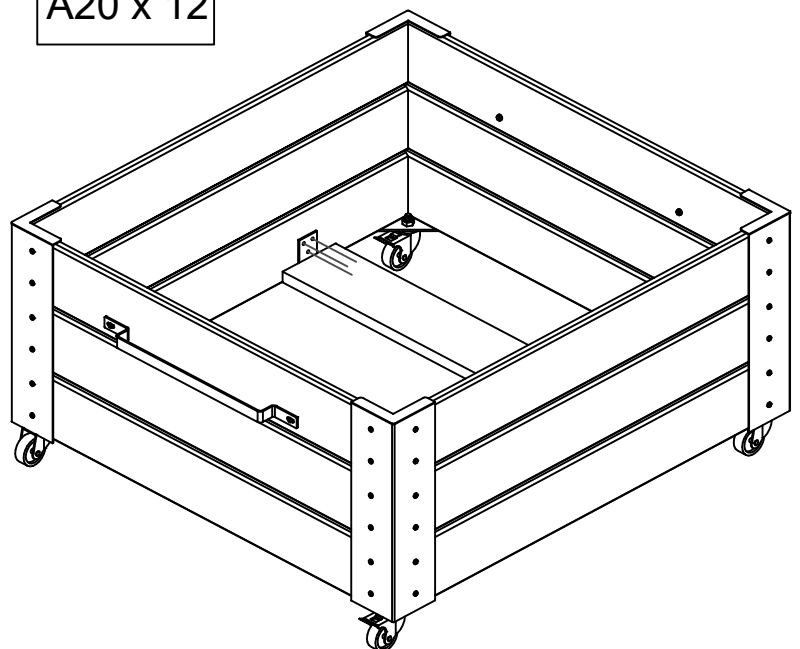
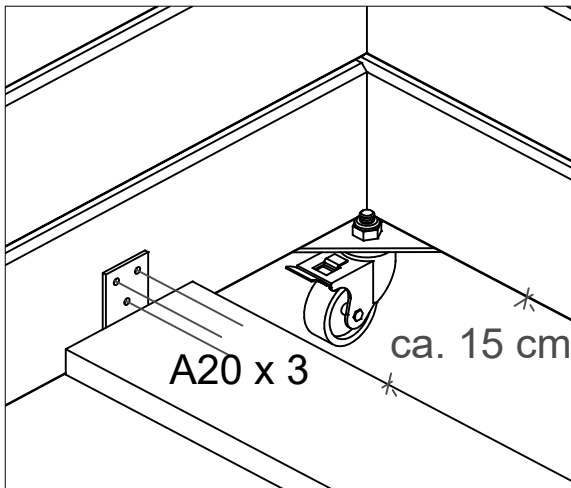

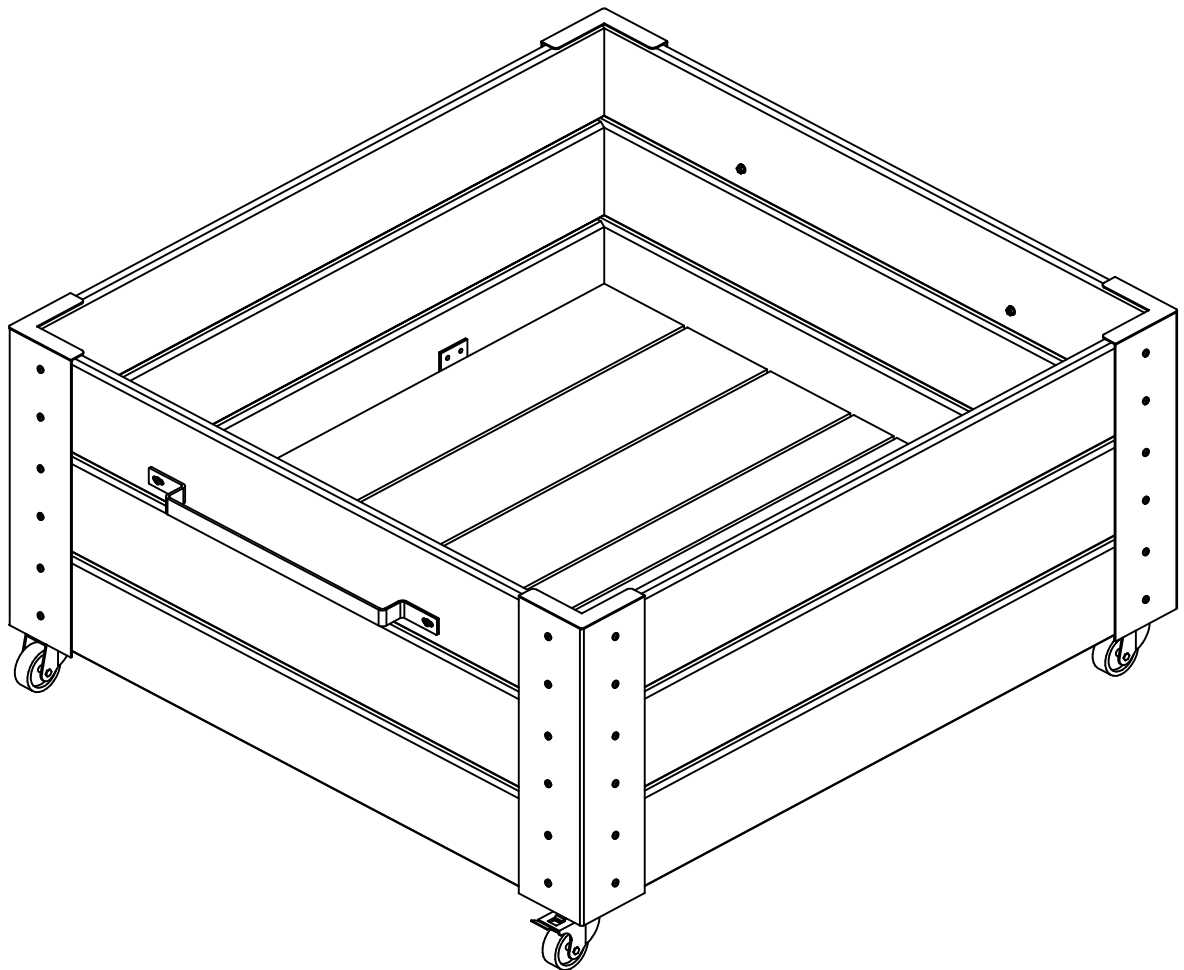
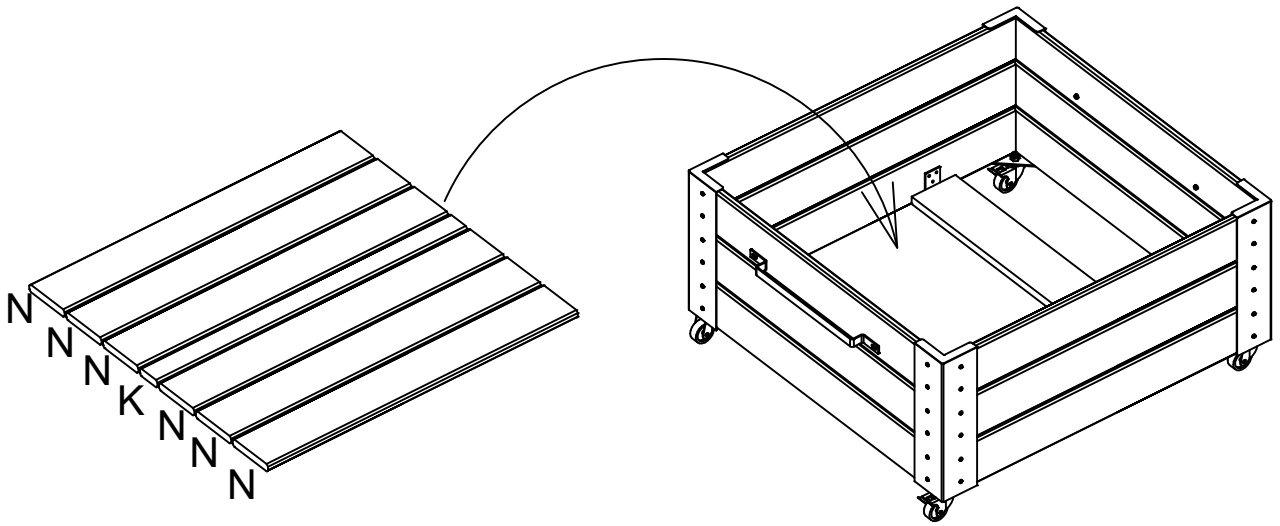

Se www.plus.dk for yderligere information og vedligehold af materialer
Weitere Informationen und Pflegehinweise finden Sie unter www.plus.dk
www.plus.dk for further information and maintenance of materials
Voir www.plus.dk pour plus d'informations et d'entretien de matériel